

SHOP DRAWING - SOUNDENTRY STC-40 ACOUSTIC DOOR

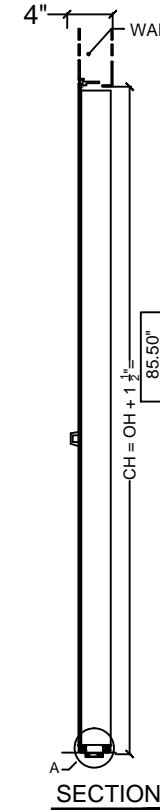
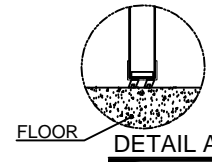
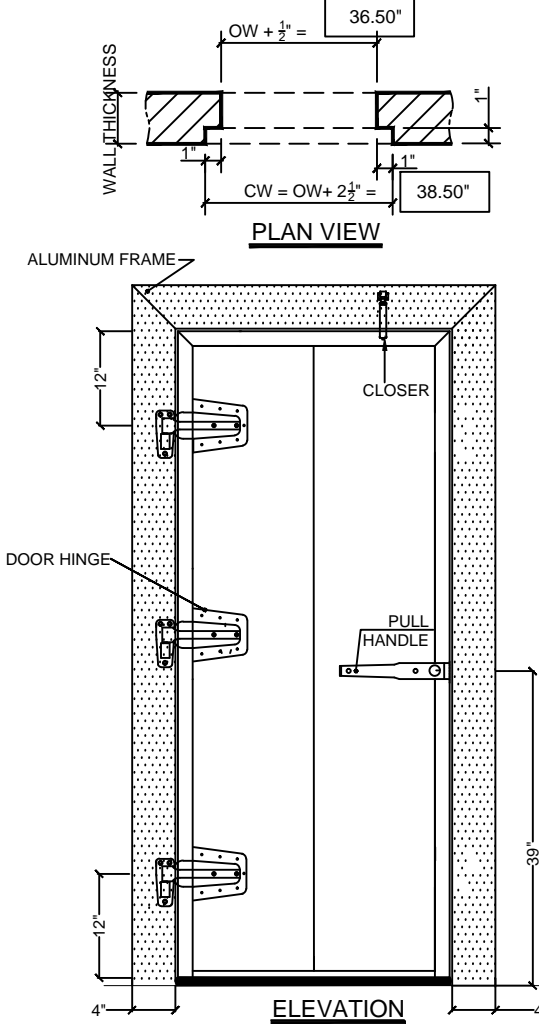
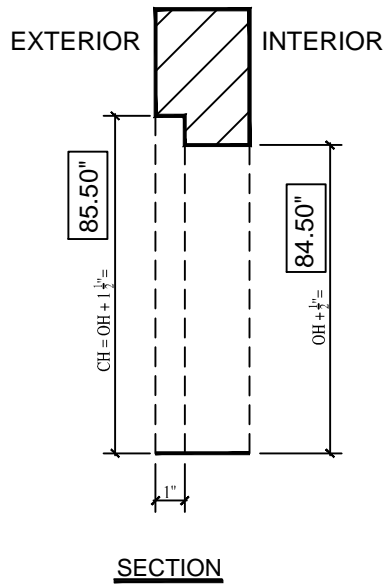
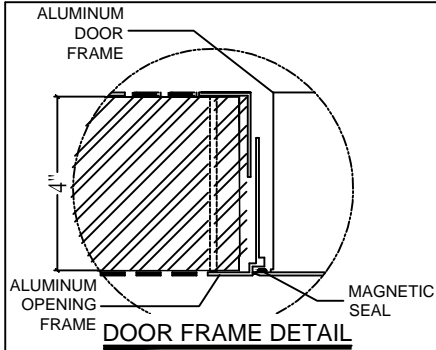

Specifications:

- * SoundEntry STC-40 acoustic door
- * Heavy-duty $\frac{5}{32}$ (4mm) aluminum opening mirror frame
- * 16ga steel exterior & interior skins
- * Enamel finish. Color to be selected by the consultant from the RAL color chart
- * Acoustic & polyurethane foam core
- * Magnetic seal on door frame perimeter
- * Bottom double blade seal on door panel
- * 2 (two) 10" cam-lift hinges
- * 1 (one) pull handle
- * 1 (one) mechanical closer

Legend

OW = OPENING WIDTH
OH = OPENING HEIGHT
CW = CLEARANCE WIDTH
CH = CLEARANCE HEIGHT

DIMENSIONS	QTY	FINISHED OPENING		REQUIRED CLEARANCE		APPROVED FOR MANUFACTURING BY:	
		WIDTH (OW)	HEIGHT (OH)	WIDTH (CW)	HEIGHT (CH)	Name:	Date:
	X	36"	84"	38.50"	85.50"	Signature:	



THERMOSTOP INC.

3775, boulevard Losch, Longueuil (Québec), Canada J3Y 5T7,
Tel.: (450) 678-8666, Fax: (450) 678-7765, www.thermostop.com

Distributor: XXXX	Date: XX-XX-XXXX	Drawn by:	Verify by:	Page:	Note : *Drawings not to scale
Customer:	Revision:	J.P.	L.H.	1/1	