

INTERIOR ELEVATION

**THERMOSTOP MODEL
SOUNDSENTRY STC-40**
DOOR THICKNESS = 4" (100 mm)

NOTE:
DOOR TO OVERLAP OPENING BY 75mm ON EACH SIDE AND AT HEADER TO ACCOMMODATE ACOUSTIC WALL COMPRESSION SEALS

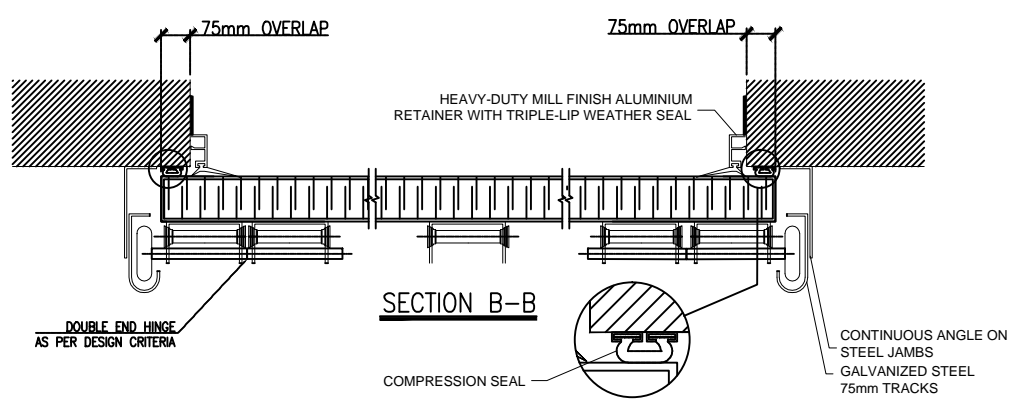

MODEL	QTY.	DOOR		No. OF PAN.	No. OF SECT.	OPERATION
		WIDTH.	HEIGHT.			
SOUND SENTRY STC 40	X	XX' X"	XX' XX"	X	X	ELECTRIC OPERATOR BY THERMOSTOP
		XXXX mm	XXXX mm			
		OPENING				
		XX' XX"	XX' XX"			

Notes:
DRAWINGS NOT TO SCALE

APPROVED FOR MANUFACTURING BY:
 Name:.....
 Signature:.....
 Date:.....

THERMOSTOP INC.
 3775 BOULEVARD LOSCH, ST-HUBERT, QUÉBEC J5Y 5T7

PROJECT NAME: XXXXXXXXX
 DISTRIBUTOR : XXXXXXXXX
 CONTRACTOR : XXXXXXXXX
 ARCHITECT : XXXXXXXXX

DATE	DRAWN BY	VERIFIED BY	QUOTE No.	DRAWING No.	REVISION
XX/XX/XXXX	X.X.	L.H.	XXXXXXX	XX/XX	XX

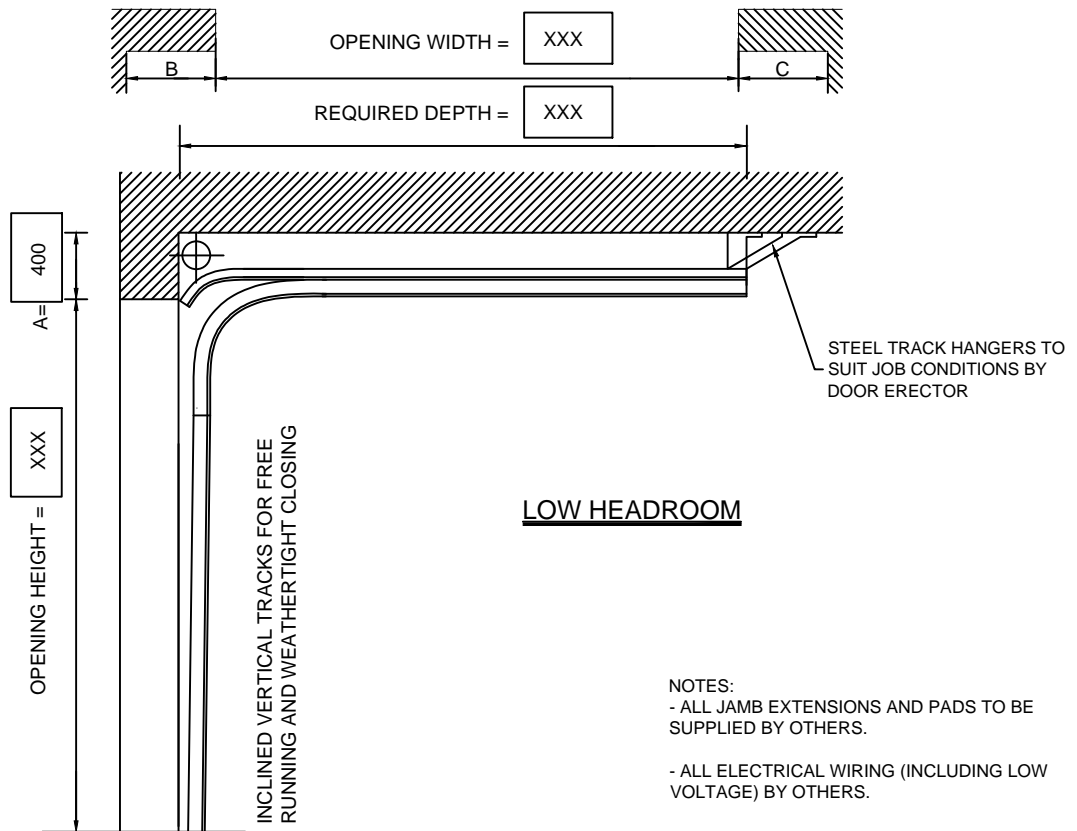
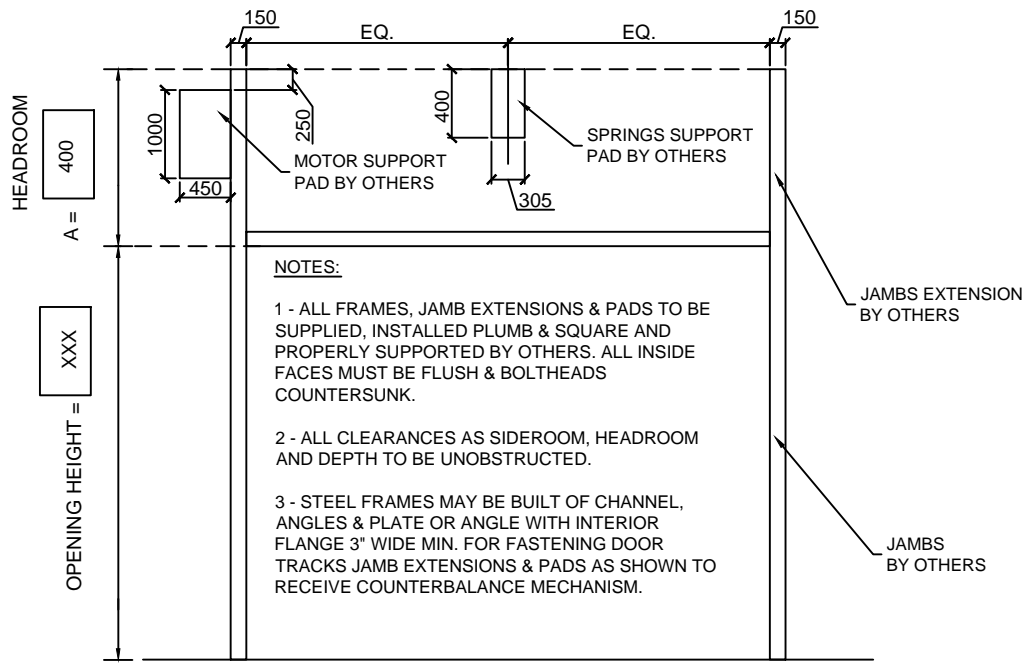

APPROVED FOR MANUFACTURING BY:
 Nom:.....
 Signature:.....
 Date:.....

MODEL	QTY.	No DOOR	CLEARANCE REQ.			DEPTH	SECT.	GLASS
			A	B	C			
SOUND SENTRY STC 40	x		400mm	600mm	150mm	XXmm	x	GLASS TYPE

NOTE:
DRAWINGS NOT TO SCALE

THERMOSTOP INC.
 3775 BOULEVARD LOSCH, ST-HUBERT, QUÉBEC J3Y 5T7
 PROJECT NAME : XXXXXXXXXXXX
 DISTRIBUTOR : XXXXXXXXXXXX
 CONTRACTOR : XXXXXXXXXXXX
 ARCHITECT : XXXXXXXXXXXX

DATE	DRAWN BY	VERIFIED BY	QUOTE No.	DRAWING No.	REVISION:
xx/xx/xxxx	x.x.	L.H.	xxxxxxx	xx/xx	xx

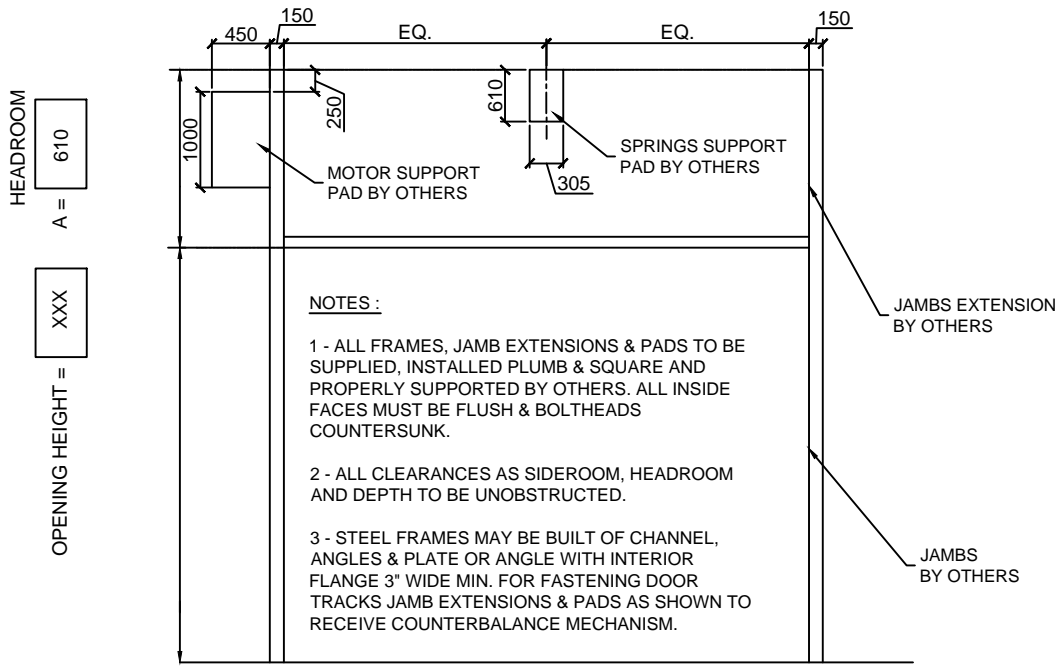

NOTES :

- 1 - ALL FRAMES, JAMB EXTENSIONS & PADS TO BE SUPPLIED, INSTALLED PLUMB & SQUARE AND PROPERLY SUPPORTED BY OTHERS. ALL INSIDE FACES MUST BE FLUSH & BOLTHEADS COUNTERSUNK.
- 2 - ALL CLEARANCES AS SIDEROOM, HEADROOM AND DEPTH TO BE UNOBSTRUCTED.
- 3 - STEEL FRAMES MAY BE BUILT OF CHANNEL, ANGLES & PLATE OR ANGLE WITH INTERIOR FLANGE 3" WIDE MIN. FOR FASTENING DOOR TRACKS JAMB EXTENSIONS & PADS AS SHOWN TO RECEIVE COUNTERBALANCE MECHANISM.

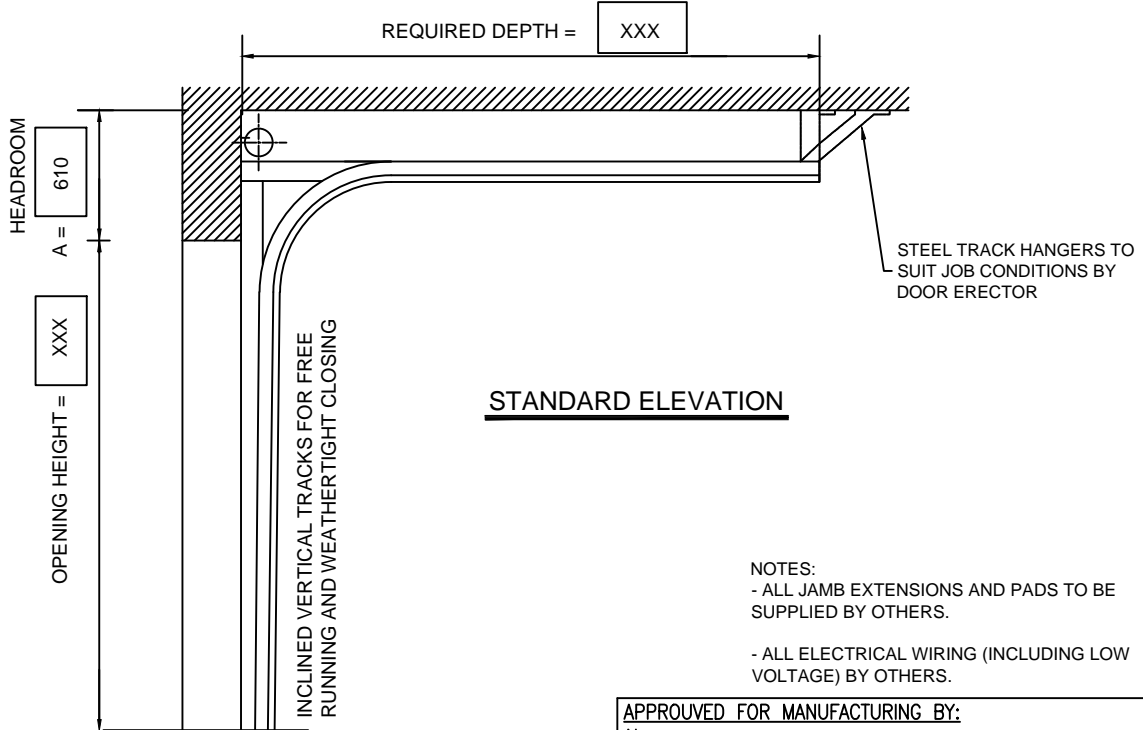
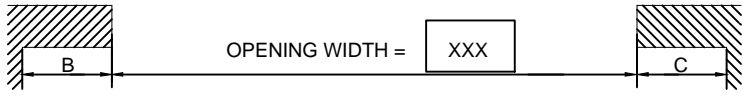

STANDARD ELEVATION

NOTES:

- ALL JAMB EXTENSIONS AND PADS TO BE SUPPLIED BY OTHERS.
- ALL ELECTRICAL WIRING (INCLUDING LOW VOLTAGE) BY OTHERS.

APPROVED FOR MANUFACTURING BY:
 Nom:.....
 Signature:.....
 Date:.....

MODEL	QTY.	No DOOR	CLEARANCE REQ.			DEPTH	SECT.	GLASS
			A	B	C			
SOUND SENTRY STC 40	X		610mm	600mm	150mm	XXmm	X	GLASS TYPE

THERMOSTOP INC.
 3775 BOULEVARD LOSCH, ST-HUBERT, QUÉBEC J3Y 5T7
 PROJECT NAME : XXXXXXXXXXXX
 DISTRIBUTOR : XXXXXXXXXXXX
 CONTRACTOR : XXXXXXXXXXXX
 ARCHITECT : XXXXXXXXXXXX

NOTE :
 DRAWINGS NOT TO SCALE
 ALL DIMENSIONS ARE IN mm

DATE	DRAWN BY	VERIFIED BY	QUOTE No.	DRAWING No.	REVISION:
xx/xx/xxxx	X.X.	L.H.	XXXXXXX	XX/XX	XX

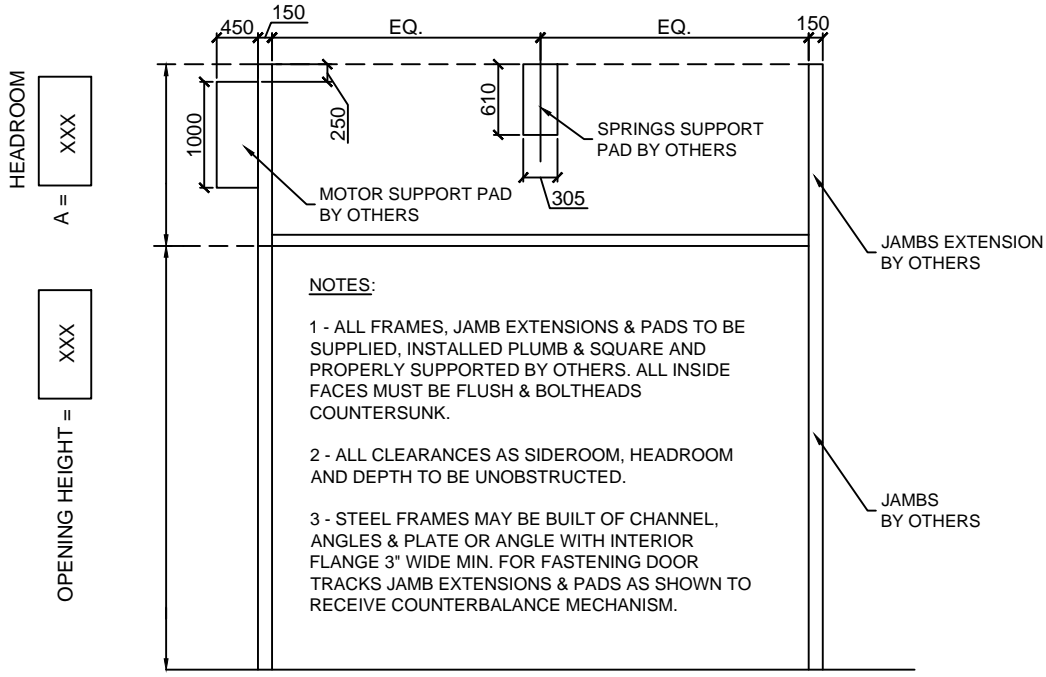

NOTES:

- 1 - ALL FRAMES, JAMB EXTENSIONS & PADS TO BE SUPPLIED, INSTALLED PLUMB & SQUARE AND PROPERLY SUPPORTED BY OTHERS. ALL INSIDE FACES MUST BE FLUSH & BOLTHEADS COUNTERSUNK.
- 2 - ALL CLEARANCES AS SIDEROOM, HEADROOM AND DEPTH TO BE UNOBSTRUCTED.
- 3 - STEEL FRAMES MAY BE BUILT OF CHANNEL, ANGLES & PLATE OR ANGLE WITH INTERIOR FLANGE 3" WIDE MIN. FOR FASTENING DOOR TRACKS JAMB EXTENSIONS & PADS AS SHOWN TO RECEIVE COUNTERBALANCE MECHANISM.

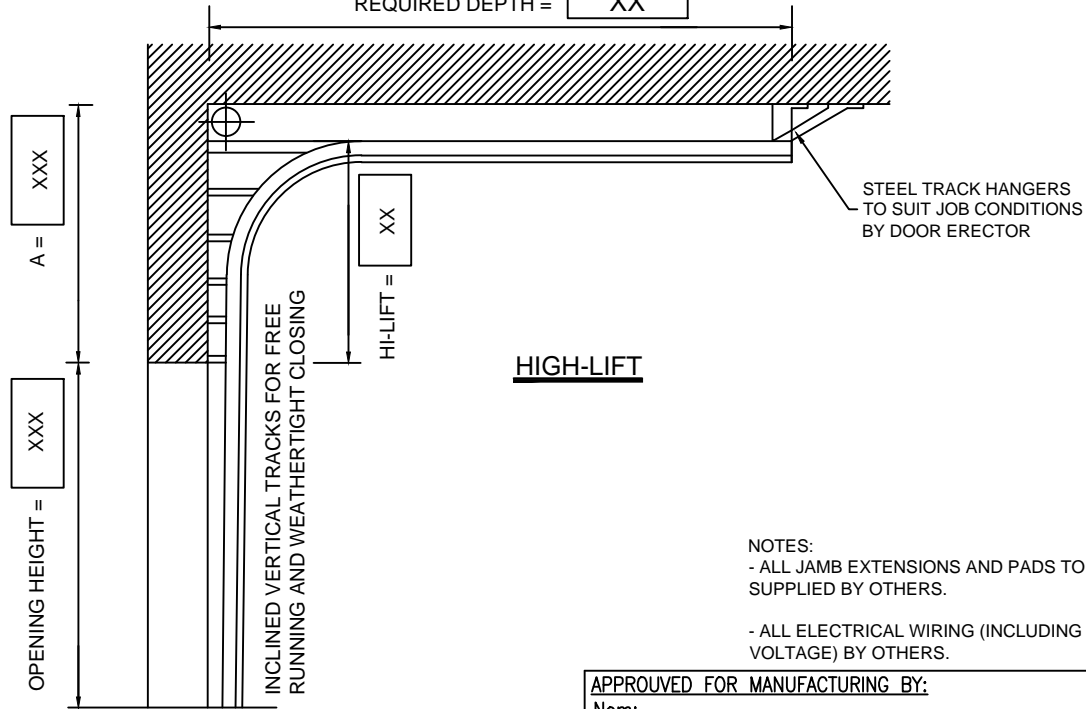
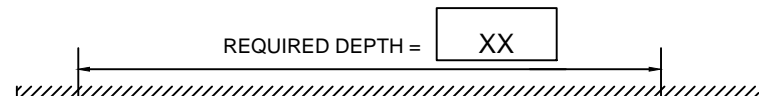
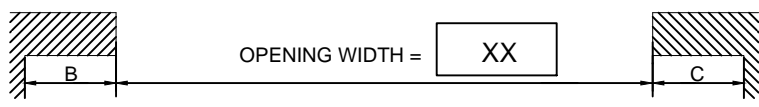

NOTES:

- ALL JAMB EXTENSIONS AND PADS TO BE SUPPLIED BY OTHERS.
- ALL ELECTRICAL WIRING (INCLUDING LOW VOLTAGE) BY OTHERS.

APPROVED FOR MANUFACTURING BY:
 Nom:.....
 Signature:.....
 Date:.....

MODEL	QTY.	No DOOR	CLEARANCE REQ.			DEPTH	SECT.	GLASS
			A	B	C			
SOUND SENTRY STC 40	X		XXmm	600mm	150mm	XXmm	X	GLASS TYPE

NOTE:
DRAWINGS NOT TO SCALE

THERMOSTOP INC.
 3775 BOULEVARD LOSCH, ST-HUBERT, QUÉBEC J3Y 5T7
 PROJECT NAME : XXXXXXXXXXXX
 DISTRIBUTOR : XXXXXXXXXXXX
 CONTRACTOR : XXXXXXXXXXXX
 ARCHITECT : XXXXXXXXXXXX

DATE	DRAWN BY	VERIFIED BY	QUOTE No.	DRAWING No.	REVISION:
xx/xx/xxxx	X.X.	L.H.	xxxxxxx	xx/xx	xx

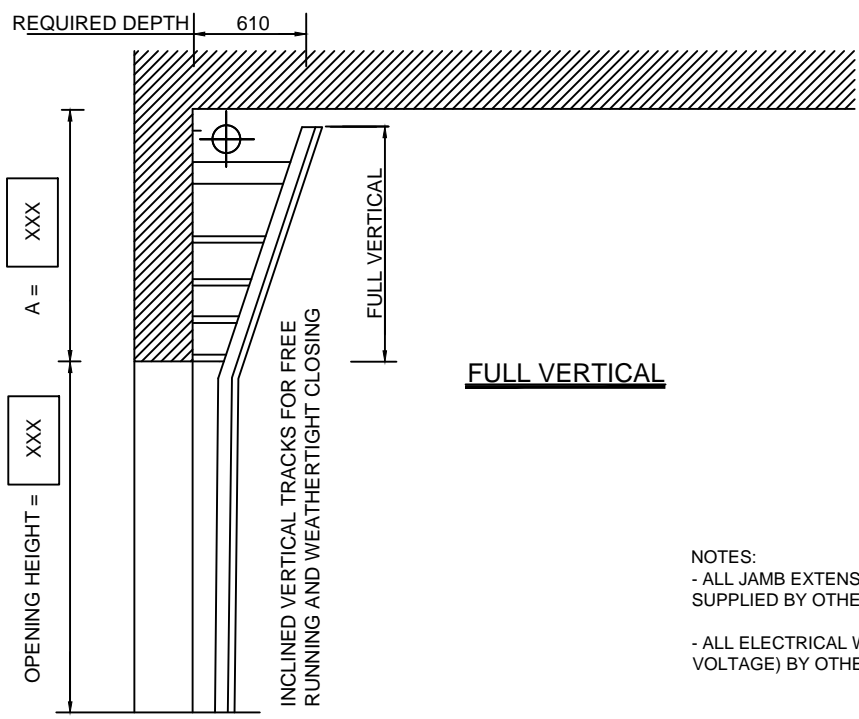
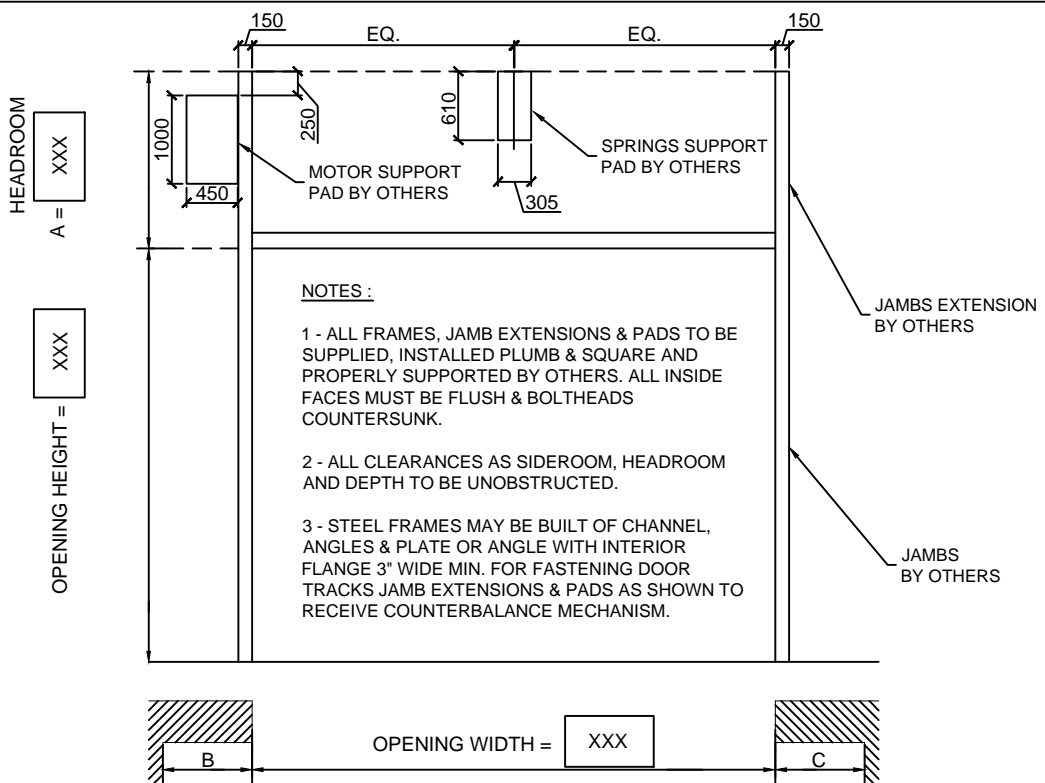

NOTES:

- ALL JAMB EXTENSIONS AND PADS TO BE SUPPLIED BY OTHERS.
- ALL ELECTRICAL WIRING (INCLUDING LOW VOLTAGE) BY OTHERS.

APPROVED FOR MANUFACTURING BY:

Nom:.....

Signature:.....

Date:.....

THERMOSTOP INC.

3775 BOULEVARD LOSCH, ST-HUBERT, QUÉBEC J3Y 5T7

PROJECT NAME : XXXXXXXXXXXX

DISTRIBUTOR : XXXXXXXXXXXX

CONTRACTOR : XXXXXXXXXXXX

ARCHITECT : XXXXXXXXXXXX

DATE	DRAWN BY	VERIFIED BY	QUOTE No.	DRAWING No.	REVISION:
XX/XX/XXXX	X.X.	L.H.	XXXXXX	XX/XX	XX

MODEL	QTY.	No DOOR	CLEARANCE REQ.			DEPTH	SECT.	GLASS
			A	B	C			
SOUND SENTRY STC 40	X		XXXmm	600mm	150mm	610mm	X	GLASS TYPE

NOTE :
DRAWINGS NOT TO SCALE